

STUDEBAKER CONTROL---MODEL S-1516

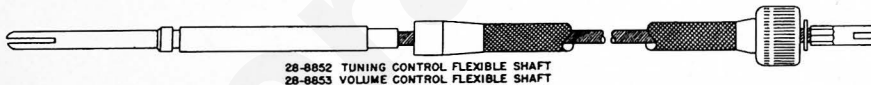
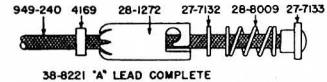
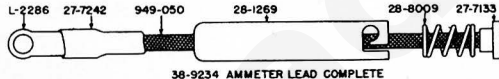
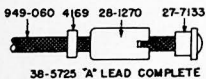
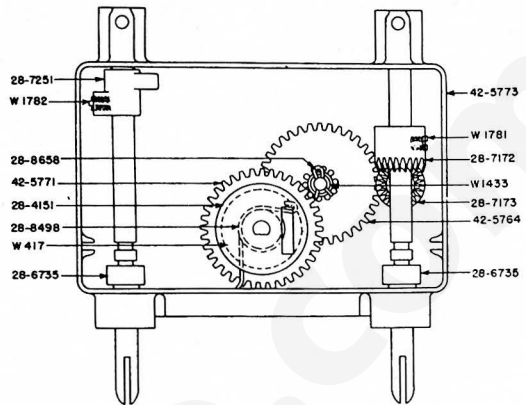
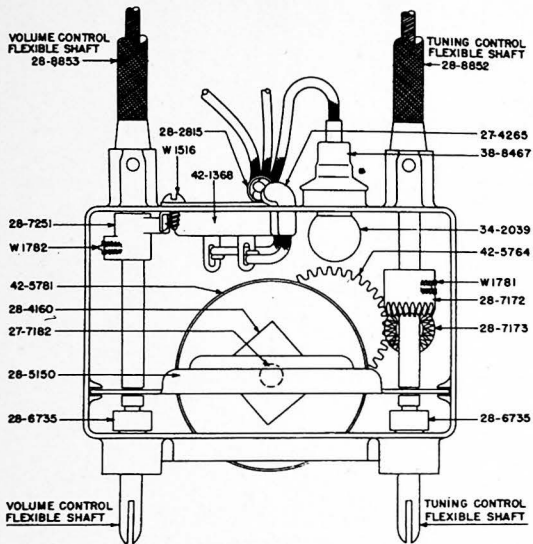

PARTS LIST AND PRICES (Prices Subject to Change Without Notice)

PART NUMBER	DESCRIPTION	LIST PRICE	PART NUMBER	DESCRIPTION	LIST PRICE
L-2286	Lug	.02	28-6773	Gland Nut	*
W-417	Washer	per 100 .50	28-7172	Miter Drive Gear	.10
W-1433	Washer	per 100 .15	28-7173	Miter Gear	.10
W-1516	Screw	per 100 1.30	28-7251	Switch Lever	.20
W-1781	Set Screw	per 100 2.00	28-7264	Knob-base	.50
W-1782	Set Screw	per 100 2.50	28-8009	Spring	per 100 .10
4169	Washer	per 100 1.20	28-8498	Anti-back Lash Spring	.10
27-4265	Sleeve	per 100 1.25	28-8658	Spring	.03
27-4689	Tuning and Volume Knob	.15	28-8852	Tuning Shaft	.90
27-7132	Washer	per 100 .40	28-8853	Volume Shaft	.90
27-7133	Ferrule	.01	34-2039	Pilot Lamp	.09
27-7182	Felt Washer	per 100 .30	38-5725	'A' Lead	*
27-7242	Sleeve	per 100 .40	38-8221	'A' Lead	.20
28-1269	Fuse Housing	.01	38-8467	Pilot Lamp Assembly	.30
28-1270	Housing	.01	38-9234	Ammeter Lead	*
28-1272	Housing	per 100 .85	42-1368	On-Off Switch	.35
28-2815	Clamp	.01	42-5764	Intermediate Gear Assembly	.20
28-4151	Washer	.02	42-5771	Drum Shaft and Gear Assembly	.15
28-4180	Spring	.01	42-5773	Housing and Stud Assembly	.85
28-5150	Shaft Retainer Plate	.05	42-5781	Dial Assembly	.35
28-6735	Bushing	*			

* Prices not available at this time.